

Installing Batten Strips for Clean Rooms

1. Remove gasket from all inside panel joints (See Figure 1). Caulk all panel joints & Speed-Lok holes with transparent silicone G. E. #RTV108 (or equivalent). Along both inside edges of batten strip, place a full length bead of silicone.

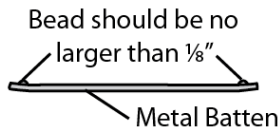

2. Allow approx. 2" from end of batten strip to top of ceiling to allow angled-batten to run along horizontally. Use $\frac{1}{8}$ " stainless steel pop rivets (017132) to attach batten strip to vertical and ceiling joints (See section view & dimensions). Space rivets along length of batten strip approx. every 6".

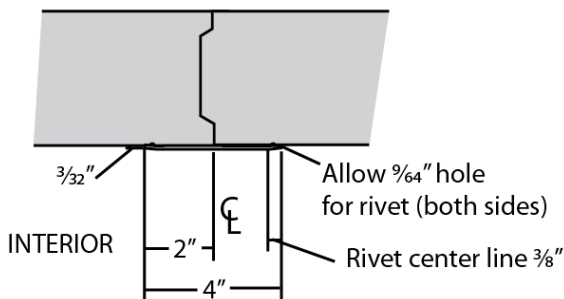

Section A-A

3. Use $\frac{1}{8}$ " stainless steel pop rivets to attach angled-batten strip to vertical-ceiling joint. Form a "butt-joint" with vertical batten strips. (See Detail A)

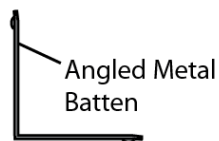

4. Seal "butt-joints" and rivet heads with silicone to form a preventive barrier.

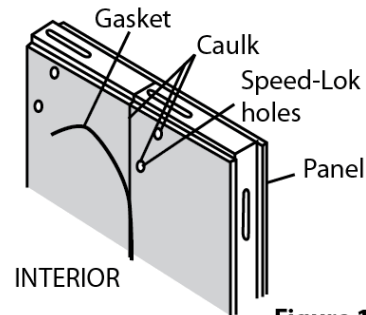

Figure 1.

